

*Instructions for SOTA  
Silver Pulser Model ZBB4*



## CONTENTS

WELCOME TO SOTA .....	2
BEFORE USING .....	2
LEARN MORE .....	2
COMPLETE UNIT INCLUDES.....	2
DO NOT USE.....	3
MICROPULSING CAUTIONS .....	3
IONIC~COLLOIDAL SILVER CAUTIONS.....	4
GENERAL CAUTION.....	4
SUMMARY OF LIGHTS .....	4
HOW TO USE THE MICROPULSING FUNCTION .....	5
All Cotton Sleeves Option.....	5
Cotton Sleeves with Velcro® Option.....	6
Turning the Unit On .....	7
How Micropulsing Should Feel .....	8
Sensitive Skin .....	8
Typical Use .....	8
HOW TO USE THE IONIC~COLLOIDAL SILVER FUNCTION .....	9
How to Assemble .....	9
How to Make Ionic~Colloidal Silver.....	9
Typical Use.....	11
ELECTRICAL SPECIFICATIONS .....	11
Power Requirements.....	11
Optional Power Input.....	11
Output Specifications.....	12
REPLACEMENT ACCESSORIES .....	12
WARRANTY.....	12
REPAIRS.....	12

• The SOTA units are consumer products designed to be used as part of a Wellness Lifestyle • The SOTA units are not medical devices nor are they intended to diagnose, treat or cure any medical or health condition • The use, safety or effectiveness of the SOTA units has not been approved by any government agency • Please consult a health practitioner for any medical or health condition. • Results using the SOTA Products will vary for each person. • Please note that all purchases of SOTA Products are deemed to be made in Penticton, BC, Canada •





## WELCOME TO SOTA

Thank you for allowing us to be a part of your Wellness Team.

The Silver Pulser is a consumer product designed to be used as part of a Wellness Lifestyle. A commitment to healthy lifestyle choices is an important factor in the journey to Wellness.

The SOTA Silver Pulser offers the benefits of gentle microcurrents of electricity and also makes Ionic~Colloidal Silver. Microcurrent stimulation supports the body's own natural electricity for more energy, health and well-being. Ionic~Colloidal Silver supports the body's natural defenses.

The Silver Pulser is designed to be used independently, but can also be used together with any of the SOTA Products.

With proper care, your Silver Pulser should provide you many years of trouble-free use.

Please understand that results will vary.

## BEFORE USING

Please read this manual thoroughly before using your Silver Pulser.

Please note information in this manual is subject to change.

For the most up-to-date manual, please visit our website [www.sota.com/manuals](http://www.sota.com/manuals).

## LEARN MORE

To learn more about the Silver Pulser we invite you to visit the SOTA website:

[www.sota.com](http://www.sota.com)

The website offers How to Videos, Frequently Asked Questions, *The SOTA Products User Guide*, SOTA News ... and more.

## COMPLETE UNIT INCLUDES

- One (1) Silver Pulser Unit
- One (1) 9-Volt Alkaline Battery
- One (1) Product Manual





## **FOR MICROPULSING APPLICATION:**

- One (1) Micropulsing Cord
- One (1) Neoprene® Velcro® Wrist Strap
- One (1) 50 ml Dark Glass Dropper Bottle

### **ALL COTTON SLEEVES OPTION**

- Three (3) Pair All Cotton Sleeves

### **COTTON SLEEVES WITH VELCRO® OPTION**

- Six (6) Pair Cotton Sleeves with Velcro®

## **FOR MAKING IONIC~COLLOIDAL SILVER:**

- One (1) Silver Wire Holder
- Two (2) Silver Wires of .9999 (4 Nine) Purity
- One (1) Green Scrub Pad

## **DO NOT USE**

1. In the following situations as safety has not been explored using the Micropulsing function:
  - a. In the case of pregnancy.
  - b. With an active implanted device such as a pacemaker, etc.
2. As with all electrical products do not use near water, when driving a car or when operating heavy equipment.

## **MICROPULSING CAUTIONS**

1. Do not place the Micropulsing Probes over skin lesions, abrasions, new scars, cuts, eruptions or sunburn.
2. Caution is advised if using potentially harmful substances such as recreational and prescription drugs, as it is not known if microcurrents will interact or if individual reactions may occur.
3. Caution is required in the following situations as a burn may occur, which could scar:
  - a. Do not apply the bare metal pins to the skin.



- b. Allowing the Cotton Sleeves to dry out while Micropulsing.
- c. Sleeping while Micropulsing, as the Cotton Sleeves may dry out.

## **IONIC~COLLOIDAL SILVER CAUTIONS**

1. We recommend taking occasional breaks from consuming Ionic~Colloidal Silver for the following two reasons:
  - a. Growth of healthy bacteria in the gut may be slowed. It may be wise to supplement with a probiotic (friendly bacteria) to replenish the gut from time to time.
  - b. Ingesting large quantities of Ionic~Colloidal Silver over a long period of time could possibly result in argyria. Argyria is a darkening of the skin – a bluish tinge. This occurs when silver is eliminated through the skin and exposed to light. Darkening of the moons of the finger nails is usually an early sign of argyria. The bluish tinge becomes especially noticeable around the eyes and nose.

The risk of argyria is considered greater with larger particle sizes. When made with a constant current unit using distilled water, the particle size remains small so the risk of argyria is considered less.

The risk of argyria is greater for those who are deficient in selenium or vitamin E and who also regularly consume large amounts of Ionic~Colloidal Silver. In addition to taking breaks from ingesting Ionic~Colloidal Silver, it may be wise to supplement with these two nutrients.

## **GENERAL CAUTION**

While this technology is generally considered safe, there exists potential for rare individual reactions that cannot reasonably be foreseen. Therefore, your use of the SOTA Products constitutes your agreement that you are responsible for your decision to use the technology.

## **SUMMARY OF LIGHTS**

Left GREEN: Flashes alternately with left RED light to indicate Micropulsing function is ready for use.

Left RED: Flashes alternately with left GREEN light to indicate Micropulsing function is ready for use.



To save batteries, the GREEN and RED lights on the left will not flash when Micropulsing cord is plugged into the unit. They will continue to flash, however, when making Ionic~Colloidal Silver.

Right GREEN: Solid light indicates Ionic~Colloidal Silver function is working.

Right RED: Solid light indicates impurities in the water or that the wires are touching when making Ionic~Colloidal Silver.

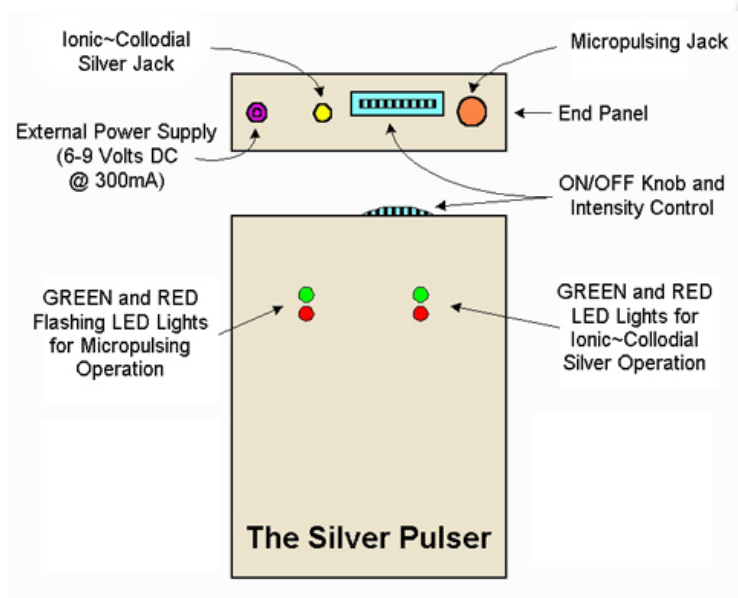

## HOW TO USE THE MICROPULSING FUNCTION

1. Place the 9-Volt Alkaline battery in the unit.
  - a. On the back of the unit, slide off the battery cover.
  - b. Attach the positive (+) and negative (-) terminals on the 9-Volt Alkaline battery to the positive (+) and negative (-) clips in the battery compartment.
  - c. Slide the 9-Volt Alkaline battery into the case and push down. Slide the cover back onto the unit.
2. Clean the wrist area to remove oils from the skin. This will allow for better conductivity.
3. Insert the Micropulsing Cord into the jack on the unit.
4. Slide the unit into the arm strap.
5. Slide the unit and the Cord up the arm to a comfortable position. Tighten the band to secure it in place.

Option: If preferred, the unit can be placed in a pocket. A longer Micropulsing Cord is needed for this option.

## ALL COTTON SLEEVES OPTION

6. Insert one probe from the Micropulsing Cord into each of the Cotton Sleeves. Use a gentle twisting motion to work the probes into the Cotton Sleeves.



7. Wet the Cotton Sleeves with water.
8. Put the Wrist Strap on.
9. Position one of the covered probes over the pulse point on the thumb side of the wrist, under the Wrist Strap.
10. Place the other covered probe in line with the pulse point on the little finger side of the wrist. This pulse point is usually harder to feel. It is located in the soft hollow on the wrist, in line with the little finger.

### COTTON SLEEVES WITH VELCRO® OPTION

6. To position the Cotton Sleeves on the Wrist Strap, place the Velcro® side of the Wrist Strap face-out rather than towards the skin.

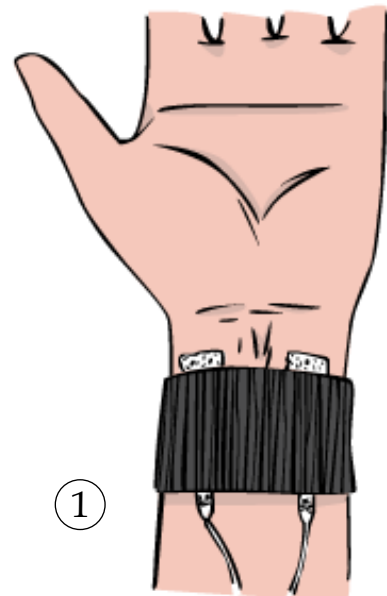

Separate the Cotton Sleeves and attach one Cotton Sleeve to the Wrist Strap in line with the pulse point on the thumb side of the wrist. Press the sleeve to the Wrist Strap to firmly adhere the sleeve in place.

Place the other Cotton Sleeve in line with the pulse point on the little finger side of the wrist. This pulse point is usually harder to feel. It is located in the soft hollow on the wrist, in line with the little finger. Press the sleeve to the Wrist Strap to firmly adhere the sleeve in place. See image 2.

Once in place, the Cotton Sleeves will stay in the right position for repeated use.

②

7. Take the Wrist Strap off.
8. Insert one probe from the Micropulsing Cord into each of the Cotton Sleeves. Use a gentle twisting motion to work the probes into the Cotton Sleeves.

9. Wet the Cotton Sleeves with water.
10. Put the Wrist Strap on so the damp Cotton Sleeves are against the skin over the pulse points. See image 1.



## TURNING THE UNIT ON

11. Turn the unit ON by rotating the thumbwheel switch clockwise. Turn the switch slowly until you feel the current. If you do not feel the current, see Notes below.

When the Micropulsing Cord is plugged into the unit, the flashing GREEN and RED lights will not be on. This helps conserve the battery.

12. When finished, turn unit OFF by rotating the thumbwheel switch fully counter-clockwise until it clicks. Do not force the ON/OFF knob past its natural stopping point.

13. Clean the wrist and apply a healing lotion to avoid irritation.

### Notes:

**Suggestions for Feeling the Current:** If the current is not felt with wet Cotton Sleeves, prepare a mild salt solution to wet the sleeves. Add only a few grains of salt to the water in the 50 ml dropper bottle. Alternatively, a conductive gel or aloe vera gel may be used instead of a salt solution. Drink enough water to keep the body well hydrated. The level of hydration may affect sensitivity.

**Care of Micropulsing Cord:** Discoloration of probes is normal. Buff occasionally to remove stains to ensure good electrical contact.

**Care of Cotton Sleeves:** Wash or rinse sleeves occasionally. Discard and replace Cotton Sleeves periodically.

**Alternatives to Cotton Sleeves:** The following items can be used in place of the Cotton Sleeves:

- a. Unbleached Paper Towel: Cut a small square of paper towel large enough to wrap around the probe 2 or 3 times. Moisten prior to use.
- b. Cotton Flannel: Cut a small square of cotton flannel and wrap around the probe with thread. Moisten prior to use.

**Testing the Micropulsing Function:** Unplug the Micropulsing Cord with the unit on. The GREEN and RED lights on the left side of the unit should flash alternately. If lights do not flash, check battery. If lights still do not flash, contact your supplier or your closest repair depot. See 'Repairs' on page 12.

**Power Supply:** When Micropulsing, the unit can only be powered by a 9-Volt battery.



## HOW MICROPULSING SHOULD FEEL

1. The sensation is a gentle pulsing. While the microcurrents should be felt, it is not necessary to turn the intensity control up to an uncomfortable level.
2. With repeated use, the ability to feel the microcurrents may change. It may be necessary to increase the intensity in order to feel the microcurrents.
3. Twitching of the fingers is normal at a higher intensity.
4. During the first weeks of use, the skin may become irritated. Over time, irritation usually decreases or disappears. Alternating wrists each session allows any irritation to better heal.

## SENSITIVE SKIN

Some individuals may be particularly sensitive to microcurrents and the irritation may continue. To minimize irritation:

1. Wash wrists thoroughly after each session and apply a healing gel or lotion such as aloe vera, vitamin E or MSM cream.
2. Micropulse for shorter periods of time until the irritation disappears.
3. Alternate wrists daily.
4. Wet the Cotton Sleeves with distilled water or Ionic~Colloidal Silver. The silver electrolyte has a healing effect. If unable to feel the current, try a commercial saline solution for the eyes. This is gentler than adding salt to the water.
5. A conductive gel or aloe vera gel added to the wet sleeves may help to reduce irritation.
6. Another option is to wrap a small square of paper towel around the probes instead of using Cotton Sleeves. Keep the paper well moistened. A small square of paper towel may last for several applications. If available, use unbleached paper towel.
7. Set the intensity dial to a comfortable level.

## TYPICAL USE

**Alternate wrists daily.**

**Length of Session:** Build up time gradually. It is best to start slowly. Start with 10 to 20 minutes a day. Increase gradually to a minimum of 2 hours each day.





**Length of Use:** Use daily for a minimum of 8 to 12 weeks. Once completed, setting a schedule for ongoing use is beneficial. Suggestions for a maintenance schedule are a) 1 to 3 times per week, b) 1 week per month, or as needed. The initial program can be repeated at any time.

**Drink Plenty of Water:** It's important to drink enough water when using the unit. Drinking ozonated water is especially helpful.

**Stop Gradually:** Reduce the amount of time each day for the last week of use. If using the 4-part SOTA Protocol, it is suggested to stop only one part of the protocol at a time.

## HOW TO USE THE IONIC~COLLOIDAL SILVER FUNCTION

### HOW TO ASSEMBLE

1. The Silver Wires fit into the two small holes in the Silver Wire Holder.
2. To insert the Silver Wires, move the spring clip away from the hole to allow the wire to slide in smoothly.
  - a. Insert as in the picture. Push the wire through. Most of the wire should be below the holder. It may be easier to insert from the underside of the holder.
  - b. Release the clip to hold the Silver Wire snugly in place.
3. Repeat the above steps for the second Silver Wire and plug the Silver Wire Holder into the Silver Pulser.

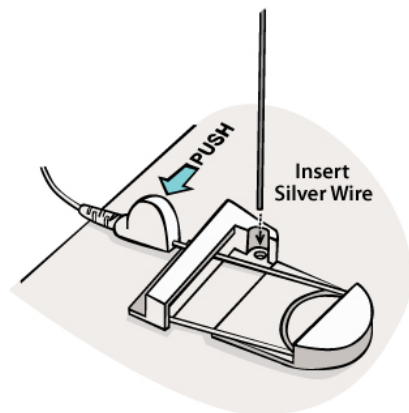

### HOW TO MAKE IONIC~COLLOIDAL SILVER

1. Heat 2 cups (500 ml) of distilled water to the boiling point – preferably in a non-metal container. Do not use a glass measuring cup on the stove top as it may explode.
2. Use a heat-resistant glass container to make Ionic~Colloidal Silver.
3. Place the Silver Wire Holder on the glass container immersing the Silver Wires. Keep them at least 25 mm or 1 inch from the bottom of the container.
4. Turn the unit ON by rotating the thumbwheel switch clockwise, until it clicks. It is not necessary to turn up the intensity.



When the Silver Wire Holder is plugged into the unit, the GREEN light on the right side of the unit will come on steady. The lights on the left side of the unit will continue to flash.

5. Stir occasionally with a non-metal utensil. Occasionally, wipe off the grey or black silver oxide that builds up on the Silver Wires.
6. Two cups (16 ounces or 500 ml) for 15 minutes will produce a 3 to 5 ppm batch of Ionic~Colloidal Silver, depending on the brand of distilled water. The concentration of silver is measured in parts per million or ppm.
7. When finished, wipe the Silver Wires with paper towel to remove residue. Buff lightly when needed to keep them free of sediment. Harsher buffing will wear away the silver faster.

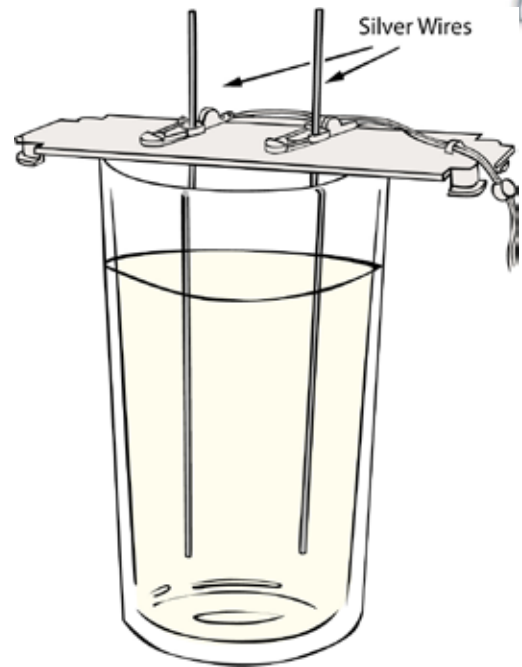

#### Notes:

**Impurities:** If the RED light on the right side of the unit comes on while making Ionic~Colloidal Silver, it means there are too many impurities in the water. Try a different brand of distilled water. The RED light also comes on if the two wires are touching.

**Color:** Ionic~Colloidal Silver remains colorless to about 5 or 6 ppm. At a slightly higher ppm it will be a pale gold color. Do not drink if it is darker than pale gold or dark grey as this indicates a higher level of impurities or larger particle sizes.

**Clarity:** The electrolyte should be clear. Do not drink if it is cloudy.

**Storage:** Pour the Ionic~Colloidal Silver into a dark glass bottle – never metal – and store in a dark, dry place. Over time, light will degrade Ionic~Colloidal Silver by turning the electrolyte grey or black.

When made and stored properly, Ionic~Colloidal Silver retains freshness for many weeks. It is suggested, however, that you use as soon as possible. If settling occurs, it is losing potency. Do not drink any sediment.

Do not freeze, refrigerate, or expose Ionic~Colloidal Silver to extremes of temperatures as its potency may be affected.



**Save on Batteries:** The unit can be powered by an AC-DC wall adaptor when making Ionic~Colloidal Silver. See 'Optional Power Input' below.

**Switch Silver Wire Positions:** The silver ions only come off the wire in the positive (+) or anode terminal into the water. To equalize the wearing of the Silver Wires, exchange the position of the wires after each use. If left in the same position, only one Silver Wire will gradually wear away.

**Replacing the Silver Wires:** The Silver Wires are of the highest grade .9999 or 99.99% or 4 Nine pure fine silver. When the SOTA pure Silver Wires wear too thin, do not replace with sterling silver, as it contains nickel, which can be toxic.

## TYPICAL USE

**Quantity:** There is no definite amount to drink. When consumed on a regular basis – daily or several times a week – it is best to drink no more than 1 to 2 ounces (30 to 60 ml) at a time.

Larger amounts of Ionic~Colloidal Silver – 1 cup or more – can be consumed for short periods of time, for example, a few weeks. It is better to take smaller amounts throughout the day rather than all at once.

**Length of Use:** 1 to 2 ounces (30 to 60 ml) or more daily for 2 or 3 months. Ionic~Colloidal Silver can be used as needed. The initial program can be repeated at any time. If using for an extended period, it is wise to take breaks.

**Strength:** Laboratory testing indicates Ionic~Colloidal Silver is effective as low as 2 ppm. When ingesting on a regular basis, it is suggested to limit the strength to less than 10 ppm.

## ELECTRICAL SPECIFICATIONS

### POWER REQUIREMENTS

Use a 9-Volt Alkaline battery for proper operation.

### OPTIONAL POWER INPUT

Both functions of the Silver Pulser can also be operated using NiMH rechargeable batteries. When purchasing rechargeable batteries, it is suggested to take the unit with you to ensure the batteries will fit the enclosure.

To use a wall adaptor for making Ionic~Colloidal Silver the output should be from 6 to 12 Volts DC with a **Tip or Center Positive** pin and a minimum of 500



mA (milliamperes) of current. The wall adaptor that comes with other SOTA units can be used for making Ionic~Colloidal Silver.

**Caution:** Exceeding the voltage rating or reverse connection may result in injury or unit failure. This will **void** the warranty.

To operate the Ionic~Colloidal Silver Function from a 12 Volt DC source, such as an automobile battery or an appropriate Solar Panel, purchase a Universal Power Cord with **Tip or Center Positive**.

## OUTPUT SPECIFICATIONS

The output voltage is a nominal 31 Volts.

**Micropulsing Application:** Frequency through probes is ~3.92 Hz or 1/2 of the Earth Schumann frequency of 7.83 Hz, (+/- 1 Hz) with a Bi-Phasic Square Wave @ 31 Volts (+/- 1 Volt) peak per cycle.

Maximum current through the probes is ~8 milliamperes into 1,000 ohms, ~12 milliamperes into a short circuit at 31 Volts peak per cycle.

**Ionic~Colloidal Silver Application:** The maximum current through the Silver Wires is 40 milliamperes (+/- 0.5 mA) at 31 VDC compliance voltage when the Silver Wires are touched together to short the circuit.

## REPLACEMENT ACCESSORIES

To replace your accessories, please contact your supplier.

## WARRANTY

The Silver Pulser covered by a three (3) year limited warranty. Please keep proof of purchase. Warranty is void if the failure is due to abuse or negligence. SOTA reserves the right to make changes to the Silver Pulser without obligation.

## REPAIRS

Please contact your supplier for return instructions. Or, for information about your closest repair depot, contact [repairs@sota.com](mailto:repairs@sota.com) or

Toll-Free: 1.800.224.0242 (Canada & USA) Tel: 1.250.770.2023

Designed, Engineered and Made in Canada.